



Hardware Installation Manual

Support : **VG-L5s**

Overall Size : 316×321×193mm (L×W×H)

Print Size : 190×130mm (L×W)

Powered by VigoTec 2018.

目录

1. PARTS LIST	1
2. INSTALLATION.....	2
3. CONTROL-BOARD AND LASER.....	6
4. NOTICE AND FAQ.....	8
5. UPDATE	9
6. PART DRAWING (NEXT PAGE).....	10

1. Parts list

Parts list of VG-L5s Laser Engraving Machine Kits

Serial N	Parts	Quantity
F1	300mm Aluminum profile	2
F2	253mm Aluminum profile	1
F3	210mm Aluminum profile	2
F4	Right angle connector for aluminum profile	4
F5	Inner hexagon screw (M5×8 , Fastening the aluminum profile)	8
F6	Nut (M5 , Fastening the aluminum profile)	8
F7	Acrylic leg	4
F8	Inner hexagon screw (M5×20 , Fastening the Acrylic leg)	4
F9	Inner hexagon screw (M5×12 , Fastening the Acrylic leg)	4
F10	Square Nut (M5 , Fastening the Acrylic leg)	4
P1	Acrylic plate A for X-Part (for laser)	1
P2	Acrylic plate B for X-Part (for stepper motor)	1
P3	Acrylic plate for Y-Part	2
P4	Inner hexagon screw (M5×20 , Fastening the Portal-Frame)	2
P5	Inner hexagon screw (M5×50 , Fastening the pulley on X-Part)	2
P6	Inner hexagon screw (M5×30 , Fastening the pulley on Y-Part)	7
P7	Non-slip Nut (M5 , Fastening the pulley)	9
P8	L connector for Portal-Frame	2
P9	Set Screw for L connector (M5)	2
P10	Inner hexagon screw for L connector (M5×12)	2

Serial N	Parts	Quantity
M1	Stepper motor	3
M2	Synchronous pulley and Set screw	3sets
M3	Inner hexagon screw for stepper motor(M3×10)	12
W1	Flat pulley	9
W2	Column for X-Part (M5×8)	5
W3	Column for Y-Part (M5×6)	6
S1	330mm Synchronous belt for X-Part	1
S2	380mm Synchronous belt for Y-Part	2
S3	Inner hexagon screw (M5×8 , Fastening the synchronous belt)	6
S4	Square Nut (M5 , Fastening the synchronous belt)	6
/	Stepper Motor wire	1
/	Protective casing	1
/	Hardware installation manual	1
/	Protective glass (Optional)	<input type="checkbox"/>
/	Control board package (Optional)	<input type="checkbox"/>
/	USB cable (Optional)	<input type="checkbox"/>
/	Laser kit (Optional)	<input type="checkbox"/>
/	Power supply (Optional)	<input type="checkbox"/>

VG-C1 Control Board Package (Optional)

Serial N	Parts	Quantity
C1	Control board	1
C2	Acrylic plate for control board A	1
C3	Acrylic plate for control board B	1
C4	Inner hexagon screw for Acrylic plate (M5×8 , Already in the Frame kit)	2
C5	Square Nut for Acrylic plate (M5 , Already in the Frame kit)	2
C6	Inner hexagon screw for control board (M3×25)	4
C7	Nut for control board (M3)	4
C8	Nylon column (M3×15)	4
/	Encryption lock	1

VG-LD Laser Package (Optional)

Serial N	Parts	Quantity
L1	Laser	1
L2	Inner hexagon screw for laser (M3×12 , Already in the Frame kit)	4
L3	Laser wire	1
L4	Inner hexagon screw (M3×25 ,Available only with the fixed-focus and 5.5w laser)	4
L5	Nut (M3 , Available only with the fixed-focus and 5.5w laser)	4

2. Installation

Please read the following installation instructions and control board instructions carefully, and pay attention to the sequence of installation. Please notice that both the Laser and Control board are

optional. The shape of parts in the following installation instructions is only as a sign. Please refer to the shape of the actual parts purchased.

Please refer to 2.2 Fixed-Focus and 5.5w Laser for the installation of fixed-focus and 5.5w laser.

2.1 Installation Instructions (Except Fixed-Focus and 5.5w Laser)

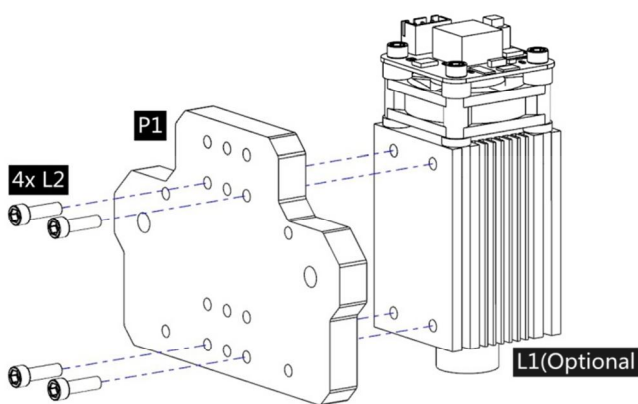

1. Assemble Laser L1 (Optional) and P1.

Pay attention to the position of Laser and Motor!

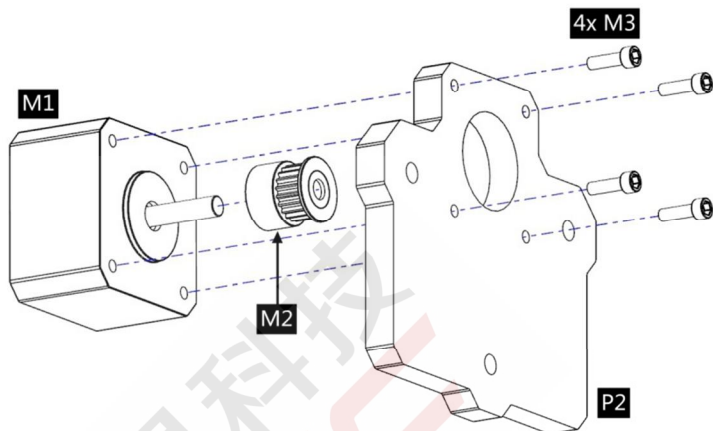

2. Assemble M1, M2 and P2.

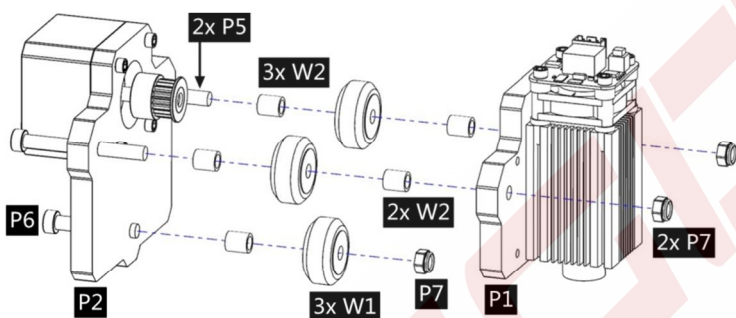

3. Assemble P2, P3, W1 and W2.

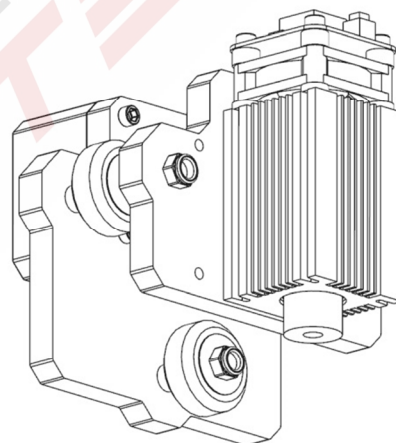

4. Assembly completed. This part is named X-Part.

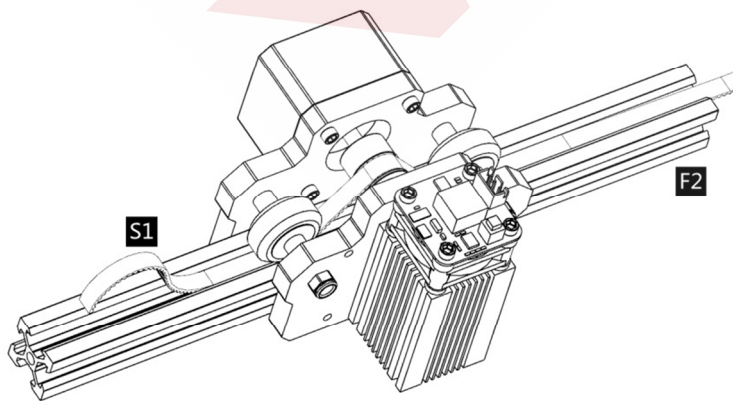

5. Slide F2 into X-Part. And pass S1 through the synchronous pulley and the Flat pulley as shown in the figure.

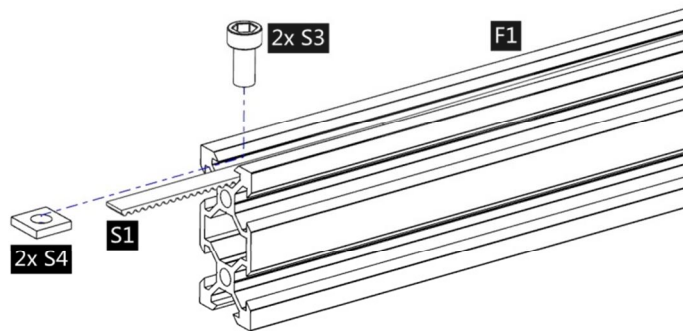

6. Fix the belt at the starting point with S4 and N2 first. Tighten up the belt and fix it on the other side with S4 and N2.

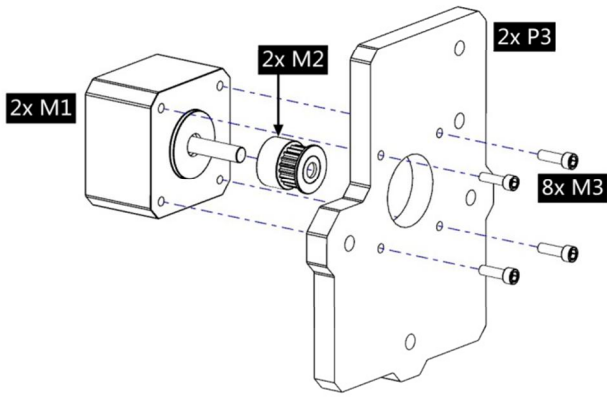

7. Assemble M1, M2 and P3. Assemble 2 sets symmetrically.

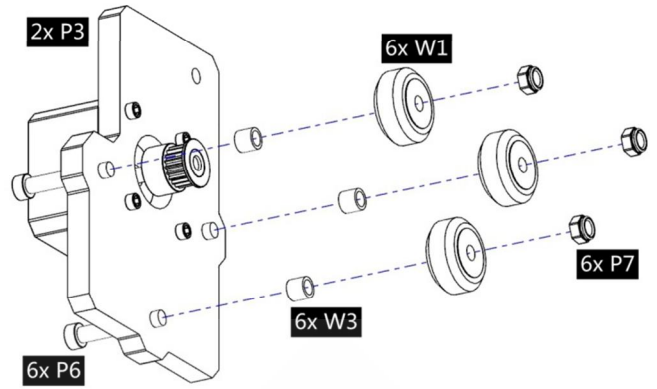

8. Assemble W1 and W3 to P3. Assemble 2 sets symmetrically.

Please note that the laser on X-Part and the motor on Y-Part are on the same side of F2.

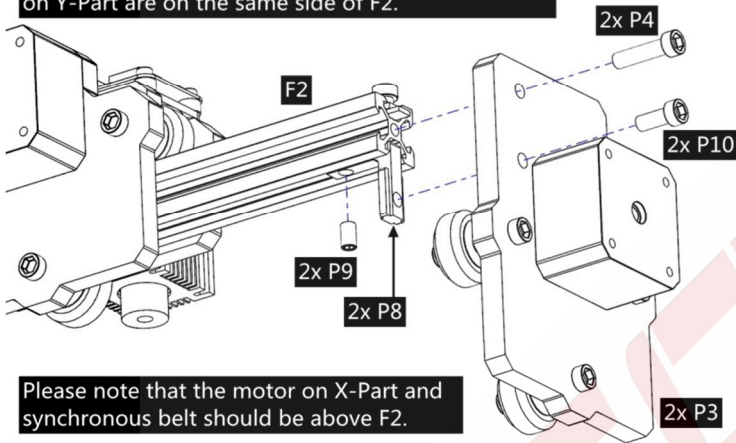

Please note that the motor on X-Part and synchronous belt should be above F2.

9. Assemble 2 sets of Y-Part to F2. Please note that the motor on X-Part and synchronous belt should be below F2. And also note that the laser on X-Part and the motor on Y-Part are on the same side of F2.

This part is named Y-Part.

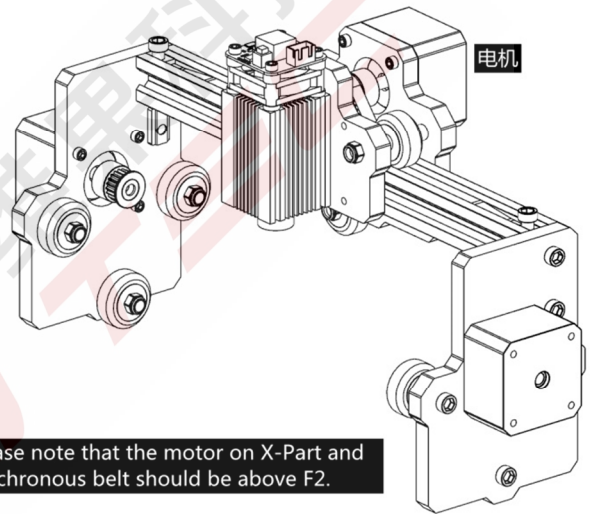

Please note that the motor on X-Part and synchronous belt should be above F2.

10. Assembly completed. This part is named Portal-Frame.

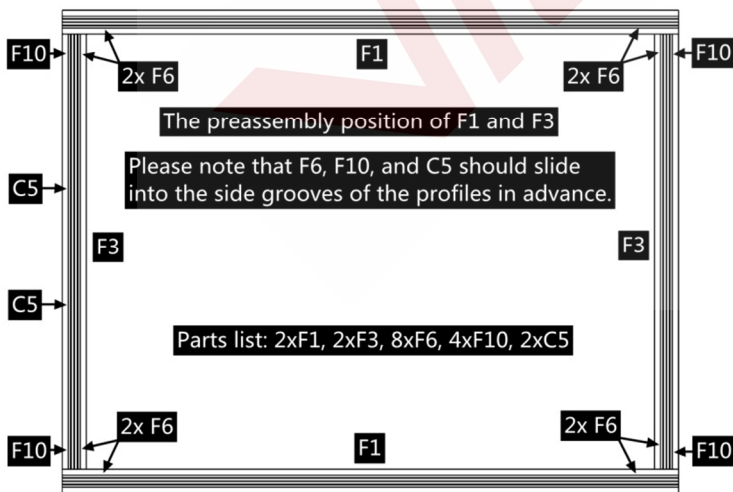

11. The preassembly position of the framework components is shown in the figure. Please note that F6, F10, and C5 should slide into the side grooves of the profiles as shown in the

It is recommended to preposition all F4 and F5 first. Lay the frame flat on a flat surface and then tighten the screw in turn.

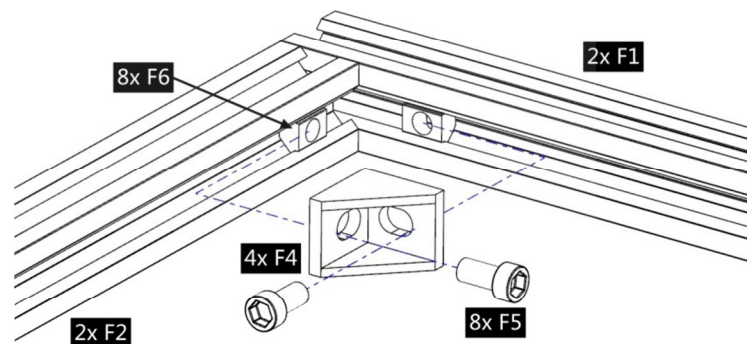

12. Connect F1 and F3 with F4 and F5. Please notice the flatness of the whole framework. It is recommended to preposition all F4 and F5 first. Lay the frame flat on a flat

figure in advance.

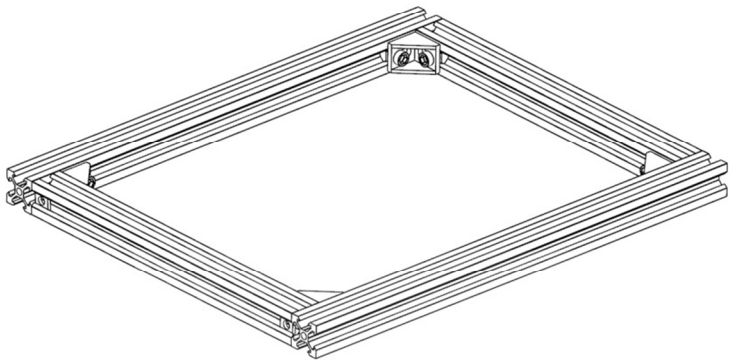

surface and then tighten the screw in turn.

Please note that C5 should be behind the Portal-Frame.

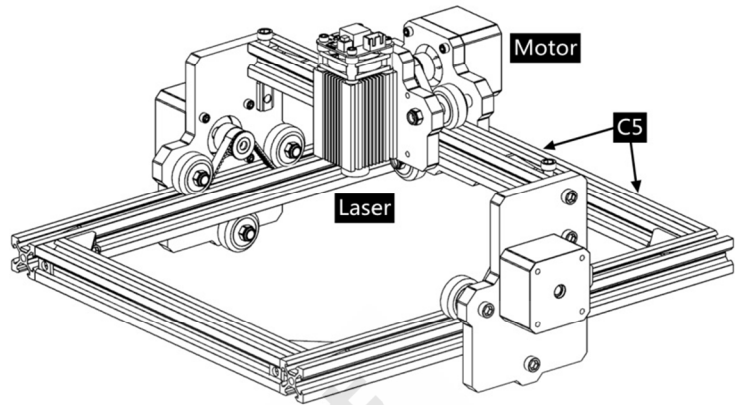

13. Assembly completed. This part is named Lower-Frame. Please notice again whether F10 and C5 are in the correct position of the groove.

14. Slide the Portal-Frame onto the side of the Lower-Frame. Please note that C5 should be behind the Portal-Frame.

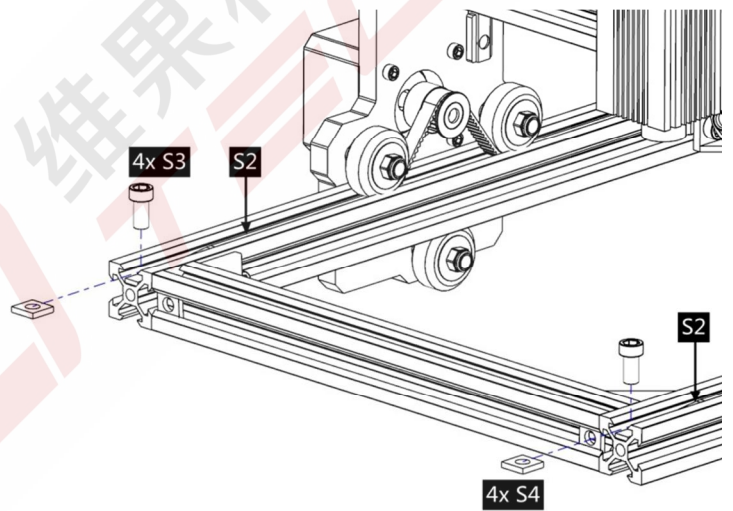
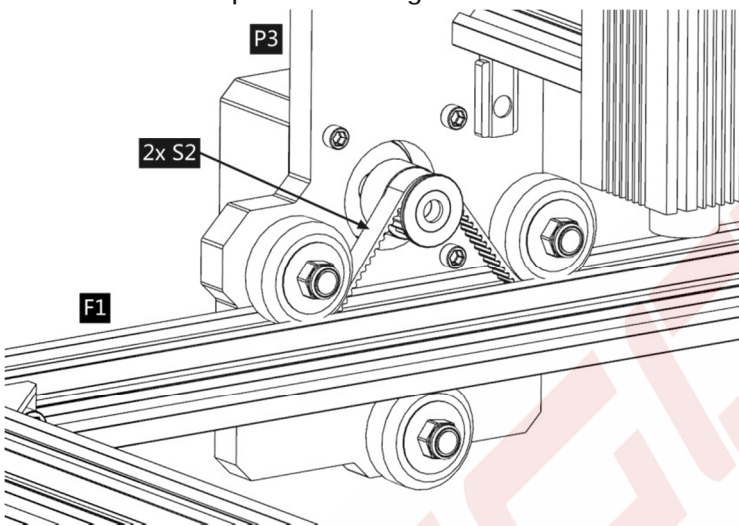

15. Assemble 2 sets of S2. Pass S2 through the synchronous pulley and the Flat pulley as shown in the figure.

16. Fix S2 at the starting point with S4 and N2 first. Then tighten up the belt and fix it on the other side with S4 and N2.

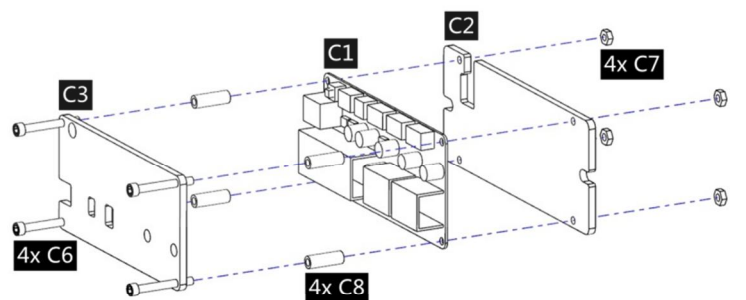
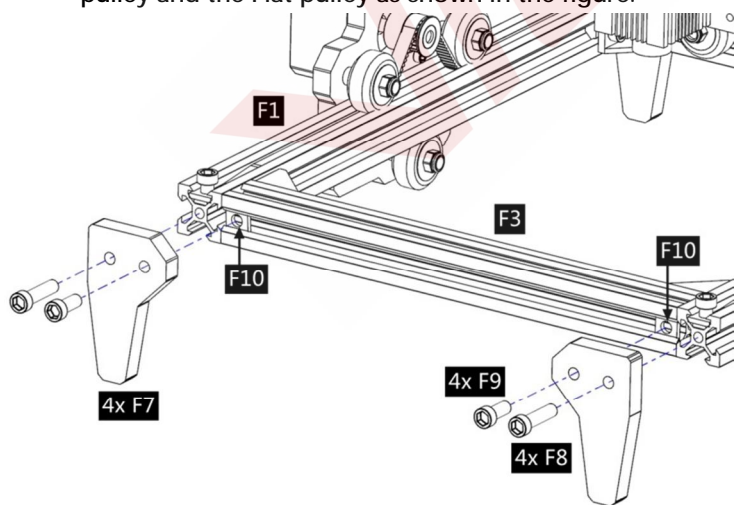

17. Assemble 4 sets of Acrylic legs F7.

18. Assemble Control board C1 (Optional) and C2, C3. This part is named Control-Part.

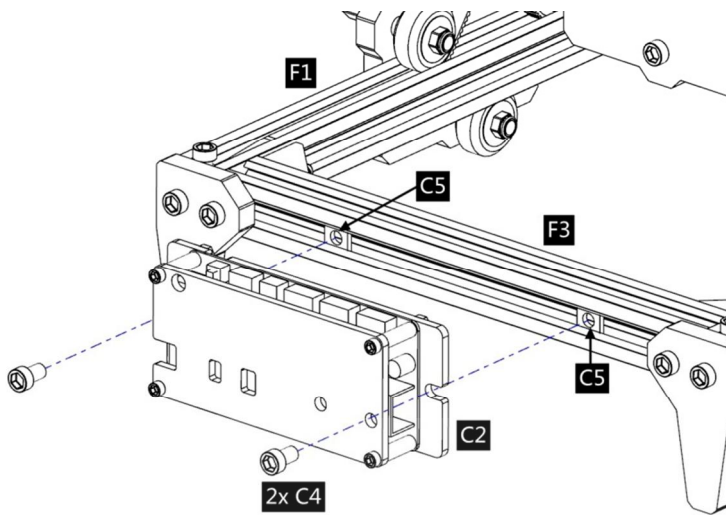

19. Assemble the Control-Part to the rear profiles F3.

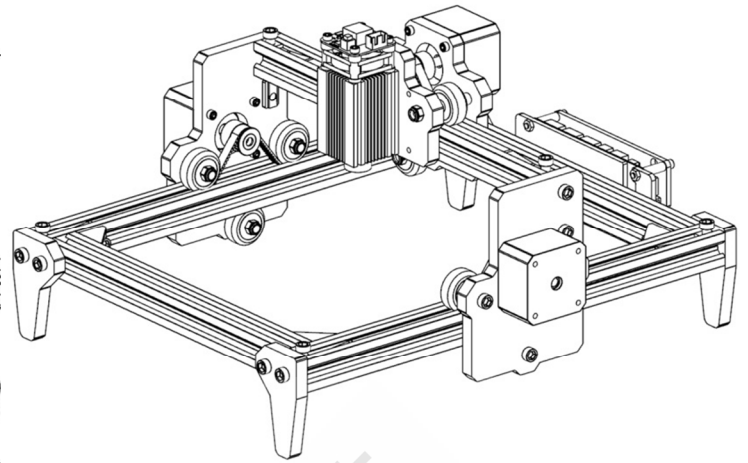

20. Final assembly completed.

2.2 Fixed-Focus and 5.5w Laser (Refer to 2.1 for the steps not shown below)

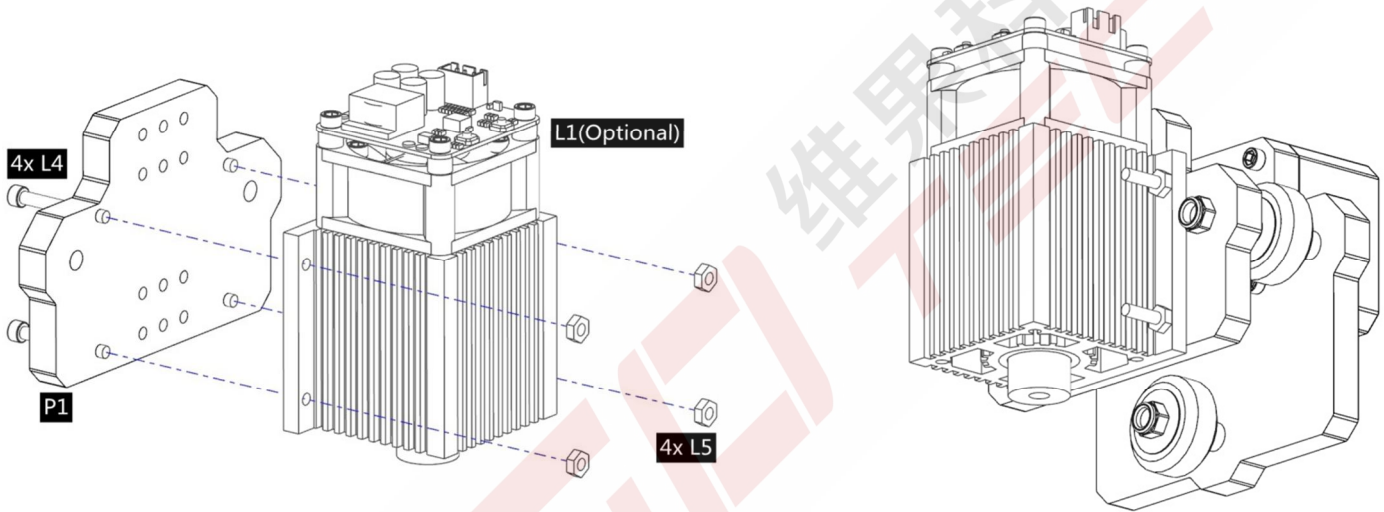

1. Assemble Laser L1 (Optional, include L4 and L5) and P1.

Please refer to the previous instructions for step 2-3.

4. Assembly completed. This part is named X-Part.
The remaining steps are the same as above. Please refer to the previous instructions.

3. Control-Board and Laser

3.1 Instructions for control board (Optional)

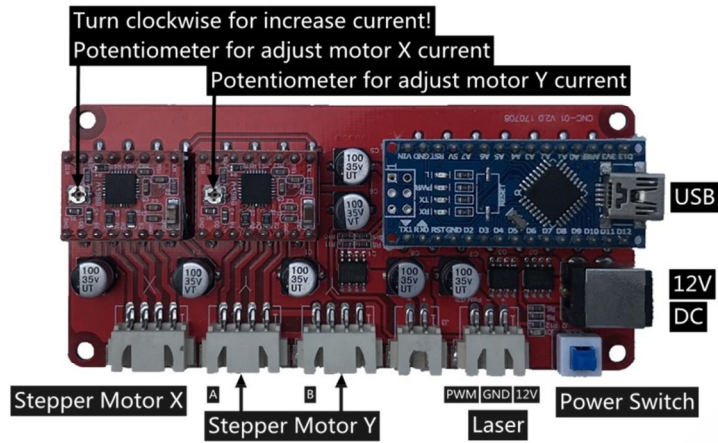

The Motor-X and Motor-Y interface on board should be connected to the X-Part and Y-part motors correspondingly. The two Y-Part motors can be connected to any of the two Motor-Y interfaces on board. It's only related to the direction of motion, and users can change the direction of Y in the software Settings. The 6Pin of the motor wire is for the motor, and the 4Pin is for the control panel.

Please connect the laser to the control board with the 3pin wire. Connect to the power supply and the computer by USB.

In general, there is no need to adjust the motor drive current.

Please focus the laser on the materials to be carved referring to the laser instructions below before starting carving.

3.2 Encryption lock (Optional).



Please connect the encryption lock to the computer before running the control software!
Please refer to the Software Installation Manual for control software instructions.

3.3 Instructions for laser (Optional).

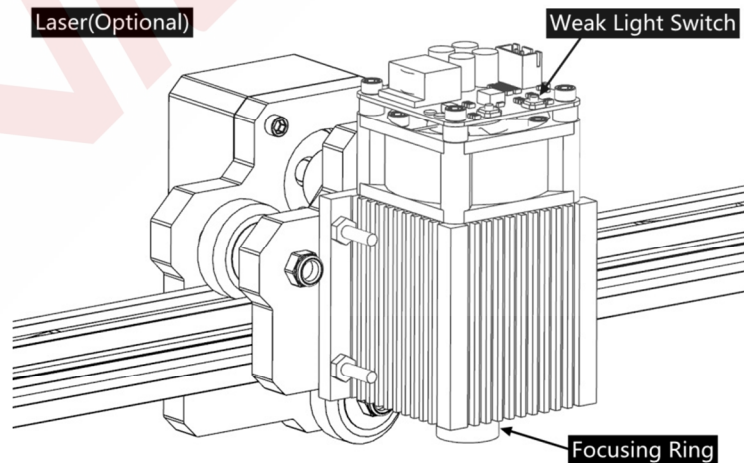

Please wear the protective glasses before operating the laser!

When all the connections are completed, turn on the power, and the laser is standby for working.

The red light on the top of the laser is continuous lighting at this time.

Turn on the weak light and adjust the focal length (except the Fixed-Focus Laser)

Please lay the materials to be carved flat under the laser. The recommended distance from laser outlet to materials is 5~10cm. Out of range may be out of focus.

Press the weak light switch on the top of the laser (Marked as ⊕). Then the red light will flash and the weak light on. Laser spots can be seen on the materials to be carved at this time. Rotate the focusing ring slowly on the laser outlet to shrink the laser spots. When the laser spots are minimized, it is the optimum state for laser carving.

After that, press the weak light switch again, and the weak light is turned off. The red light on the top of the laser is continuous lighting at this time, and the laser is standby for working.

It is important to understand that this weak light switch on the top of the laser is not controlled by control software. So be sure to switch back to normal (make sure that weak light is off) before you start carving.

Fixed-Focus Laser

The focal length of a Fixed-Focus Laser is not adjustable, and the focal length is fixed about 18mm. Be sure to use the accessory column for focal length to determine the distance from the materials to be carved to the laser outlet.

4. Notice and FAQ

(1).The shape of all parts above in this description is only as a sign. There may be a difference between the actual parts and the parts in the installation instructions. Please refer to the shape of the actual parts purchased.

(2).Please pay attention to the sequence of the installation steps to avoid repeated disassembly.

(3). Make sure hibernate and sleep are disabled when working long hours. This feature will blocks communication between control software and encryption lock, and the software will shut down. In this case, it may cause the laser to continue to glow out of control, and burning on the table.

(4). It is strictly prohibited to use this machine unattended.

(5). Make sure to wear protective glasses before operating the laser.

FAQ

The control software cannot be opened	Please check whether the encryption lock is connected to the computer; Please check whether the system is Win7 or above.
Wrong control respond	Please power off the device and shut down the software, then restart both. If useless, please try below. Please restore the device by click Restore in setting, then click Model Select and choose the device you used to reset parameters.

<p>The carving is not good or there is no burned trace</p>	<p>Please check whether the focal length of laser is in the recommended distance.</p> <p>Please check whether the laser focus is at a minimum.</p> <p>Please check whether the object to be caved is laid flat.</p> <p>Please check whether the laser is in weak light mode.</p> <p>Please check whether the power indicator light on the control panel is continuous lighting.</p> <p>Please check whether the motors are working properly.</p>
<p>The stepper motors are not working properly</p>	<p>Please check whether the connection between the three motors and control board is correct.</p> <p>Please check for any irrelevant stuff on the slide to block movement.</p> <p>Please check whether the motor drive current is normal. Too little current causes the motors to stall. Too much current makes the motors to vibrate, and causes the movement of the machine or materials to be carved.</p> <p>Please check whether the power indicator light on the control panel is continuous lighting.</p>

5. Update

Our software will be updated continuously.

Please visit our website: www.vigotec.cn for more new products and software.

Warning:

Strictly prohibit laser irradiation of the eyes!

Strictly prohibit watching laser without wearing protective glasses!

Strictly prohibit using by children!

Strictly prohibit using this machine unattended!

Powered by VigoTec 2018.

Attachment: List of Accessories for VG-L5s Tool box

Figure	Name	Introductions	Quantity
—	Tool box	—	1
	Screw	M5×8	16
		M5×12	6
		M5×20	6
		M5×30	7
		M5×50	2
		M3×10(for Motor)	12
		M3×12(for Laser)	4
		M5, Set Screw	2
L connector	Cooperate with Set Screw	2	
	Nut	M5,Trapezoidal,for Frames	8
		M5,Non-slip Nut	9
		M5,Square Nut	12
	Synchronous pulley and Set screw	2GT,20 teeth,M5	3sets
	Column	M5×6	6
	Inner Hexagon Wrench	2mm	1
		2.5mm	1
		4mm	1
	Nut Wrench	8#	1

6. Part Drawing (Next page)

6. Part Drawing (L5s Ratio 1:1)

